

# A network model for the control of the differentiation process in Th cells

Luis Mendoza\*

*Serono Pharmaceutical Research Institute, 14, Chemin des Aulx, 1228 Plan-les-Ouates, Geneva, Switzerland*

Received 10 August 2005; received in revised form 21 September 2005; accepted 4 October 2005

## Abstract

T helper cells differentiate from a precursor type, Th0, to either the Th1 or Th2 phenotypes. While a number of molecules are known to participate in this process, it is not completely understood how they regulate each other to ensure differentiation. This article presents the core regulatory network controlling the differentiation of Th cells, reconstructed from published molecular data. This network encompasses 17 nodes, namely IFN- $\gamma$ , IL-4, IL-12, IL-18, IFN- $\beta$ , IFN- $\gamma$ R, IL-4R, IL-12R, IL-18R, IFN- $\beta$ R, STAT-1, STAT-6, STAT-4, IRAK, SOCS-1, GATA-3, and T-bet, as well as their cross-regulatory interactions. The reconstructed network was modeled as a discrete dynamical system, and analyzed in terms of its constituent feedback loops. The stable steady states of the Th network model are consistent with the stable molecular patterns of activation observed in wild type and mutant Th0, Th1 and Th2 cells.

© 2005 Elsevier Ireland Ltd. All rights reserved.

**Keywords:** Th lymphocytes; Discrete dynamical system; Feedback loop; Regulatory network; Logical modeling

## 1. Introduction

The vertebrate immune system encompasses various cell populations, which include antigen presenting cells, natural killer cells, and B and T lymphocytes. Among the latter, CD4<sup>+</sup> T cells can be further sub-classified as T helper 1 (Th1) or Th2 cells, which originate from a common precursor known as Th0 (Murphy and Reiner, 2002; Agnello et al., 2003). These cells differ in their pattern of cytokine secretion. Functionally, the molecules secreted by Th1 cells lead to cell-mediated and inflammatory immune responses, while those secreted by Th2 cells intervene in humoral immune responses. Importantly, cytokines produced by mature Th cells promote their own differentiation, and at the same time inhibit

the proliferation of each other (Fig. 1). The resulting activatory and inhibitory cross-regulations create a complex network at the molecular and cellular levels. Many of the molecules that play a key role in this process are known, but their precise regulatory interactions are not well established (see for example, Figs. 1–3 in Glimcher and Murphy, 2000). Furthermore, it is not known if the reported molecules and interactions are sufficient to explain the pattern of differentiation from one precursor cell type (Th0), into two differentiated types (Th1 and Th2). Understanding the molecular mechanism of this differentiation process is relevant because cytokines secreted by Th cells are involved in diverse pathologies. In general, immune reactions biased towards Th1 responses may result in autoimmune diseases, while enhanced Th2 responses may cause allergic reactions.

This paper presents a qualitative model for the regulatory network controlling the Th1/Th2 differentiation

\* Tel.: +41 22 7069915; fax: +41 22 7946965.  
E-mail address: [luis.mendoza@serono.com](mailto:luis.mendoza@serono.com).

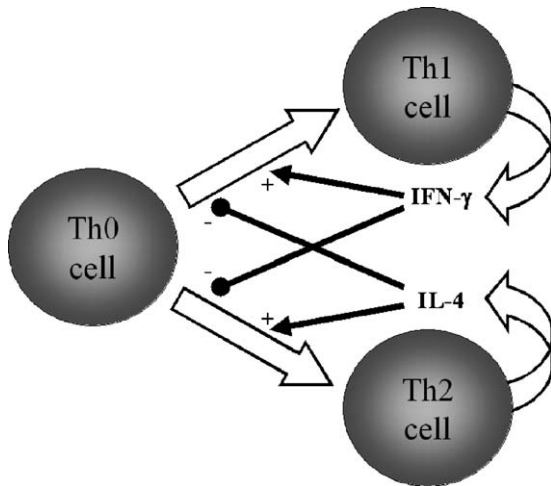

Fig. 1. Differentiation of Th cells. Th0 cells differentiate into Th1 or Th2 cells, a process that is regulated by the cytokines secreted by the Th cells themselves.

process. The strategy used is based on a bottom-up approach, starting with an extensive overview of published molecular data to reconstruct the underlying biological network. The behavior of the resulting network was then studied using the generalized logical method (Thomas, 1991; Thomas et al., 1995), which allows a qualitative analysis of the dynamical properties of the system, while focusing on the feedback loops (or ‘circuits’) present in the network. This approach has been previously applied to various regulatory networks, including those involved in organ differentiation control in the flowers of *Arabidopsis thaliana* (Mendoza et al., 1999), and in the initiation of segmentation during *Drosophila melanogaster* embryogenesis (Thieffry and Sánchez, 2002; Sánchez and Thieffry, 2003).

### 1.1. Molecular basis of the Th network

The following paragraphs summarize published evidence used to recover the interactions in the Th regulatory network (Fig. 2). The information comes from in vitro experiments with mouse or human cells. However, there are two features of GATA-3 that seem to exist exclusively in mouse (see ahead); these are clearly specified in the text. Th1 cells produce IFN- $\gamma$  (Hamalainen et al., 2001; Murphy and Reiner, 2002), which acts on its target cells by binding to a multimeric cell-membrane receptor (IFN- $\gamma$ R) present in the Th1 cells themselves (Novelli et al., 1997; Rigamonti et al., 2000). The transduction of the IFN- $\gamma$ /IFN- $\gamma$ R signal acts via STAT-1 (Kotenko and Pestka, 2000), which can be activated by a number of ligands besides IFN- $\gamma$ , including IFN- $\beta$  via

IFN- $\beta$ R (Goodbourn et al., 2000). In contrast, STAT-1 cannot be activated by IL-4 (Moriggi et al., 1998), but STAT-1 itself plays a role in the modulation of IL-4 signals, being an intermediate of the negative regulation exerted by IFN- $\gamma$  over IL-4 (Elser et al., 2002). Further down the IFN- $\gamma$  signal transduction pathway is SOCS-1, a molecule that is highly expressed in Th1 cells, but barely detectable in Th0 and Th2 cells (Chen et al., 2000; Egwuagu et al., 2002). Indeed, IFN- $\gamma$  strongly induces SOCS-1 via a STAT-1-dependent pathway (Saito et al., 2000). SOCS-1, in turn, influences both the IFN- $\gamma$  and IL-4 pathways. Furthermore, SOCS-1 is a negative regulator of IFN- $\gamma$  signaling, blocking the interaction of IFN- $\gamma$ R and STAT-1 (Diehl et al., 2000). Finally, it is known that SOCS-1 is able to block the capacity of IL-4R to generate a signaling in response to IL-4 (Losman et al., 1999).

T-bet is a transcription factor detected in Th1, but not in Th0 or Th2 cells. Its expression is up-regulated by IFN- $\gamma$ , through a STAT-1-dependent mechanism (Lighvani et al., 2001). In turn, T-bet is an IFN- $\gamma$  activator (Szabo et al., 2000), thus creating an indirect positive feedback. Furthermore, it has been shown that ectopic T-bet is able to induce the transcription of its own gene (Mullen et al., 2001). This effect occurs in the absence of a functional IFN- $\gamma$ /IFN- $\gamma$ R signaling pathway, since it is observed even in Th2 cells (Afkarian et al., 2002), and hence suggests an IFN- $\gamma$ -independent positive feedback of T-bet. Finally, T-bet expression is able to re-differentiate Th2 cells into Th1 cells in an IFN- $\gamma$ R-independent manner (Szabo et al., 2000). This means that T-bet is able to activate SOCS-1, either directly or indirectly, via a pathway independent of IFN- $\gamma$ R/STAT-1.

For their part, Th2 cells express IL-4, which is indeed a major determinant of the Th2 phenotype (Agnello et al., 2003). The main signal transduction pathway that mediates IL-4 signals is well documented (Nelms et al., 1999), and starts by the binding of IL-4 to its receptor, IL-4R, which is also preferentially expressed in Th2 cells (Hamalainen et al., 2001). The IL-4R signal is transduced by STAT-6, which in turn activates GATA-3 (Murphy and Reiner, 2002). GATA-3 itself is capable of inducing IL-4 (Ouyang et al., 2000), thus establishing a positive feedback loop. The influence of the IL-4 pathway on the IFN- $\gamma$  pathway seems to be mediated by GATA-3, since T-bet mRNA is down-regulated by virus-induced GATA-3 expression (Usui et al., 2003). Conversely, T-bet is capable of inhibiting GATA-3 (Szabo et al., 2000). The mutual inhibition between GATA-3 and T-bet ensures that Th1 and Th2 cells express one or the other molecule (T-bet in Th1, and GATA-3 in Th2), but not both.

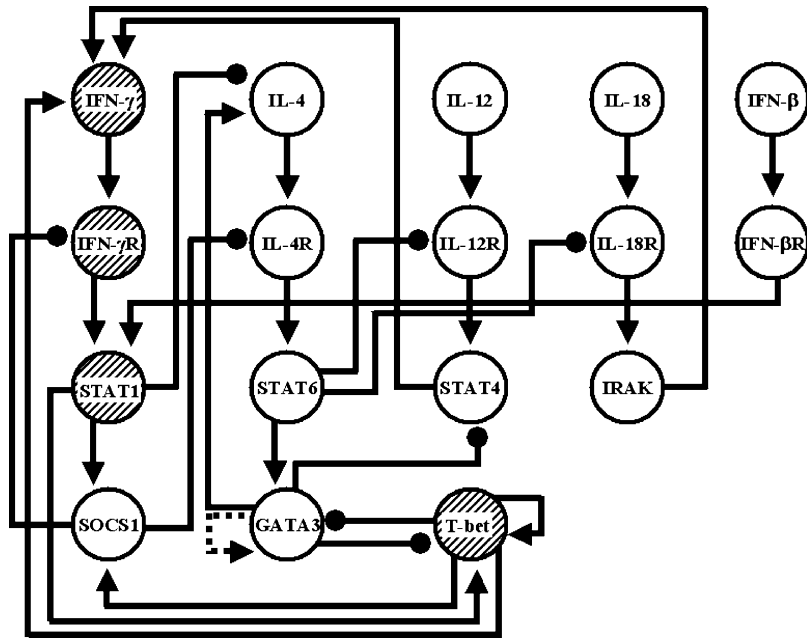

Fig. 2. The Th regulatory network. The positive (activatory) interactions are represented by pointed arrows, and negative (inhibitory) interactions by circle-ending arrows. The dotted arrow emphasizes that the self-activation of GATA-3 is considered only in the mouse case. Dashed circles show the nodes that are modeled as ternary variables, whereas open circles correspond to the nodes modeled as binary variables.

Some studies point to the possible existence of a GATA-3 auto-activatory loop, based on the expression of endogenous GATA-3 induced by retroviral GATA-3, even in the absence of IL-4 and STAT-6 (Ouyang et al., 2000; Ranganath and Murphy, 2001; Zhou et al., 2001; Zhou and Ouyang, 2003). Experimental data indeed supports the existence of a positive circuit involving GATA-3 that excludes IL-4 and STAT-6, specifically in mouse cells (Zhou and Ouyang, 2003). In human cells, however, the situation is not so clear. Activation of the IL-12 pathway is sufficient to turn T-bet on in a self-sustained way, with a concomitant inhibition of GATA-3 expression. But, the reverse is not true; GATA-3 cannot be transiently activated, leading to a self-sustained GATA-3 expression and a T-bet inhibition (Smits et al., 2001). The lack of self-sustained activation argues against the existence of a direct GATA-3 positive feedback loop, and rather points towards an indirect positive loop mediated by T-bet. Since there is no unequivocal evidence to assert the existence of a GATA-3 auto-activatory loop in human cells, this paper covers two variants of the Th model: the first excluding, and the second including a GATA3 auto-activatory loop (dotted arrow in Fig. 2). The second variant of the model includes two items apparently exclusively present in the mouse; first, the possible existence of an auto-activatory circuit in GATA-3 (Zhou and Ouyang, 2003); and second the inability to inhibit the

GATA-3 pathway by signals that activate T-bet (Smits et al., 2001).

Apart from the key pathways involving IFN- $\gamma$  and IL-4, there are other molecules known to affect the differentiation of Th cells. IL-12 is produced by monocytes and dendritic cells, and promotes the development of Th1 cells (Trinchieri, 1995). A functional IL-12 receptor is present in Th0 and Th1, but not in Th2 cells (Szabo et al., 1995), and its signaling is mediated by STAT-4 (Thierfelder et al., 1996). For its part, several observations support the idea that STAT-4 could directly activate IFN- $\gamma$ : (i) IL-12 is an important molecule for the differentiation towards Th1 cells; (ii) the IL-12 signal is mediated by STAT-4; (iii) Th1 cells produce IFN- $\gamma$ ; and (iv) over-expression of STAT-4 induces IFN- $\gamma$  secretion (Usui et al., 2003). Moreover, the inhibition of IFN- $\gamma$  by GATA-3 seems to be mediated by STAT-4. The over-expression of GATA-3 reduces the production of IFN- $\gamma$ , but the simultaneous over-expression of GATA-3 and STAT-4 leads to the production of high quantities of IFN- $\gamma$  (Usui et al., 2003).

The IL-12 signaling pathway can be blocked by IL-4 in at least two ways, pointing to an inhibition at multiple steps of the pathway. First, IL-4 reduces the expression of one subunit of the IL-12 receptor, namely IL-12R $\beta$ 2 (Szabo et al., 1997). Since this is a change at the expression level, the IL-4 effect should be mediated by STAT-6.

Hence, the inhibition of IL-4 to IL-12R is mediated by STAT-6. Furthermore, GATA-3 is capable of reducing the expression of STAT-4 (Usui et al., 2003), pointing to an indirect inhibition from IL-4, via GATA-3, to the IL-12 signaling pathway.

Finally, IL-18 is a cytokine produced by many cell types, promoting IFN- $\gamma$  production by Th cells (Swain, 2001). IL-18 binds its receptor, IL-18R, which acts through IRAK (Chang et al., 2000). Interestingly, IL-12 and IL-18 act synergistically to increase IFN- $\gamma$  production, but using different pathways (Kanakaraj et al., 1999; Akira, 2000). As in the case of IL-12, IL-4 is able to block the IL-18 signaling in a STAT-6-dependent manner, by down-regulating a subunit of the IL-18 receptor (Smeltz et al., 2001).

### 1.2. Logical modeling of the Th network

As a first approximation, the nodes of a regulatory network can be considered as binary elements; that is, ‘ON/OFF switches’. This kind of modeling greatly simplifies the dynamical analysis of the corresponding network. Despite their apparent simplicity, Boolean networks share many qualitative features with systems modeled using continuous functions. The generalized logical formalism used in this study extends the Boolean formalism by allowing the variables to take multiple discrete values (for an ample description of the method, see Thomas, 1991; Thomas et al., 1995; Thomas and Kaufman, 2001). Specifically, a logical variable is associated to each node of the network, with one specific value assigned to each distinct functional level.

Quantitative data on the expression of the molecules represented in the Th regulatory network is currently lacking. Hence, the model describes the functional levels of the nodes in terms of discrete variables with two or three different levels (Fig. 2), depending on the qualitative experimental information available in the literature. Thirteen nodes are limited to two levels of functionality (‘low’ and ‘high’), whereas four others have three associated functional values (‘low’, ‘medium’, and ‘high’). This notation is equivalent to assigning values of ‘0’ and ‘1’ in the first case, and ‘0’, ‘1’ and ‘2’ in the second. The specific activity level attainable by an element depends of the values of the variables acting as input to the node under consideration. The corresponding transition rules were derived from the experimental data mentioned in Section 1.1, completed by considerations discussed in the following paragraphs.

The choice of naming the levels of activation as low, medium or high, instead of giving numbers, was

meant to stress the qualitative nature of these levels of activation. Since the model does not explicitly incorporate any specific mechanism of activation or inhibition, these levels should be interpreted in the broadest sense possible, that is, either the molecule is present and functioning at its full capacity (‘high’ state), at an intermediate value (‘medium’ state), or the molecule is absent or not functional (‘low’ state). The molecular mechanisms that render a molecule functional or non-functional are not explicitly included in the model, and might thus be multi-factorial. For example, a high level of IL-12R node means that all the subunits of the receptor are present, correctly assembled, and that IL-12 is bound in sufficient quantities so as to activate IL-12R, thus starting a signaling cascade. On the other hand, a low IL-12R level means that either one or more of its subunits are absent, or that the complex is not properly assembled, or that it is inhibited, or even that IL-12 is not functionally bound to the receptor. Any of these possibilities result in the absence of a signal originating from IL-12R.

On the basis of published experimental information, one can assign three, rather than two, levels of activation to the nodes representing IFN- $\gamma$ , IFN- $\gamma$ R, STAT1 and T-bet. The evidence for these qualitative assignments can be summarized as follows. IL-12 or IL-18 can induce the secretion of IFN- $\gamma$  in Th1 cells; however, a simultaneous treatment of IL-12 and IL-18 causes a significantly larger secretion of IFN- $\gamma$  than any of the two cytokines alone (Yang et al., 2001). Hence, two levels of significant activation are introduced for the IFN- $\gamma$  node to reflect the cooperative effect of IL-12 and IL-18 on it. For its part, IFN- $\gamma$ R is made up of two types of chains, IFN- $\gamma$ R1 and IFN- $\gamma$ R2. Flow cytometry experiments have shown the ability of both chains to be expressed at low or high levels (Bernabei et al., 2001), with the former promoting proliferation and the latter causing apoptosis. Furthermore, Western blot analysis reveals that increasing doses of IFN- $\gamma$  result in corresponding increased levels of STAT-1 in the nucleus (Ohmori and Hamilton, 1997). Therefore, the levels of activity of STAT-1 in the Th model should reflect those of IFN- $\gamma$  and IFN- $\gamma$ R, amounting to three different levels of activation. Finally, T-bet is clearly regulated by the IFN- $\gamma$  signaling pathway, and its level is markedly reduced, but not eliminated in either IFN- $\gamma$ <sup>-</sup> or STAT-1<sup>-</sup> loss-of-function mutant cells (Lighvani et al., 2001). This evidence can be easily captured in the Th model by assigning three levels of functionality to the T-bet node.

The logical analysis focuses on the role of feedback loops, also referred to as circuits. Circuits are defined as

circular chains of interactions, such that each element of a circuit influences its own future level of activation. Whenever specific signs can be associated with each interaction, a given circuit can be classified as either positive or negative. Positive circuits contain zero or an even number of negative interactions, while negative circuits have an odd number of negative interactions. In a positive circuit, each element exerts a positive effect on itself, while in a negative circuit element has a negative effect upon itself. Consequently, positive and negative circuits have different dynamical properties. A positive feedback loop can give rise to multistationarity, whereas a negative loop can generate damped or sustained oscillations. Depending on the dynamical rules of the system, the multistationary or oscillatory behavior may be present in only a restricted region of the phase space, or even totally absent. Because of this characteristic, if a positive circuit does generate multiple stable steady states, even if in a restricted region of the state space, then the circuit is said to be functional. Similarly, if a negative circuit does generate an oscillatory behavior, even if only in a limited region of the state space, then the circuit is said to be functional.

The functionality of a circuit is analyzed by assessing the steadiness of its so-called characteristic state. The characteristic state is defined as the state located at the activity thresholds of all the elements that participate in the circuit. For the elements with two states of activation, the threshold ‘S’ lies between the low (‘l’) and high (‘h’) levels. Similarly, for elements with three states of activation, a first threshold ‘S<sup>1</sup>’ separates the low and medium (‘m’) levels, whereas a second threshold ‘S<sup>2</sup>’ separates the levels ‘m’ and ‘h’. Whenever the characteristic state of a circuit is steady, the circuit itself it is considered to be functional (Thomas, 1991; Thomas et al., 1995; Thomas and Kaufman, 2001).

## 2. Results and discussion

The regulatory graph (Fig. 2) presented here constitutes the most extensive attempt to model the regulatory network controlling the differentiation of Th lymphocytes to date. The topology of the network, and the associated dynamical rules (Table 1), were derived from published experimental data, summarized in Section 1.1, after a careful analysis to distinguish direct from indirect regulatory interactions. A preliminary Boolean model of the network has been published earlier, without a proper discussion of the supporting data and model predictions (Remy et al., in press). The present version of the Th model is composed of 17 nodes, which represent various kinds of molecules: secreted cytokines, receptors,

signal transducers and transcription factors. Such molecular heterogeneity implies different types of regulatory mechanisms, which remain implicit in the model for the sake of simplicity. The following sections consider the results of two variants of the model, depending on the exclusion or inclusion of an auto-activatory loop for GATA-3, corresponding to the human and mouse situations, respectively.

### 2.1. Qualitative dynamical analysis of the Th network

Excluding the GATA-3 auto-activatory loop, the regulatory graph of Fig. 2 contains a total of 22 feedback circuits, 19 positive and 3 negative (see Supplementary Table 1). The transition rules of Table 1 were used to study the functionality of these circuits as explained in Section 1.2, with the result that only eight of the 22 circuits are functional in at least one region of the state space. Importantly, only positive loops are functional. This characteristic of the model is relevant, because functional negative feedback loops would generate damped or sustained oscillations (Thomas et al., 1995), and their absence in the dynamics of the model is consistent with the lack of experimentally observed oscillations in Th cells. Remember, however, that the Th model contains a relative low number of molecules, and a discrete system is only a qualitative simplification of the biological system. It is entirely possible that further refinements of the model may unveil some functional domains for these, or other, negative circuits, thus unveiling their biological role in the differentiation process.

As mentioned before, a functional positive circuit generates multistationarity. In terms of the state space, a positive circuit creates a separatrix in the region of the state space in which it is functional. Furthermore, the absence of oscillations due to a lack of functional feedback loops implies that the basins of attraction lead to fixed-point attractors. These attractors can be found by enumerating all the possible activation states of the network (a total of 663552), and evaluating which of these states remain unchanged when the rules of Table 1 are applied to the system. The Th model has the following four attractors, respectively, characterized by:

1. Low levels of activation of all network nodes.
2. High levels of IFN- $\gamma$ , SOCS-1 and T-bet, medium levels of IFN- $\gamma$ R and STAT-1 (all other nodes at low levels).
3. Medium levels of IFN- $\gamma$ , IFN- $\gamma$ R, STAT-1 and T-bet; a high level of SOCS-1 (all other nodes at low levels).

Table 1  
Dynamical rules for the Th model

Node	Activation state as a function of the regulatory nodes		
IFN- $\gamma$	$K_{IFN-\gamma} = 1$ $K_{IFN-\gamma}(IRAK^h) = 1$	$K_{IFN-\gamma}(STAT-4^h) = m$ $K_{IFN-\gamma}(STAT-4^h, T-bet^m) = m$ $K_{IFN-\gamma}(IRAK^h, T-bet^m) = m$ $K_{IFN-\gamma}(T-bet^m) = m$	$K_{IFN-\gamma}(STAT-4^h, IRAK^h) = h$ $K_{IFN-\gamma}(STAT-4^h, IRAK^h, T-bet^m) = h$ $K_{IFN-\gamma}(STAT-4^h, IRAK^h, T-bet^h) = h$ $K_{IFN-\gamma}(STAT-4^h, T-bet^h) = h$ $K_{IFN-\gamma}(IRAK^h, T-bet^h) = h$ $K_{IFN-\gamma}(T-bet^h) = h$
IL-4	$K_{IL-4} = 1$ $K_{IL-4}(STAT-1^m) = 1$ $K_{IL-4}(STAT-1^m, GATA-3^h) = 1$ $K_{IL-4}(STAT-1^h) = 1$ $K_{IL-4}(STAT-1^h, GATA-3^h) = 1$		$K_{IL-4}(GATA-3^h) = h$
IL-12	$K_{IL-12} = 1$		
IL-18	$K_{IL-18} = 1$		
IFN- $\beta$	$K_{IFN-\beta} = 1$		
IFN- $\gamma$ R	$K_{IFN-\gamma R} = 1$ $K_{IFN-\gamma R}(SOCS-1^h) = 1$	$K_{IFN-\gamma R}(IFN-\gamma^m) = m$ $K_{IFN-\gamma R}(IFN-\gamma^m, SOCS-1^h) = m$ $K_{IFN-\gamma R}(IFN-\gamma^h, SOCS-1^h) = m$	$K_{IFN-\gamma R}(IFN-\gamma^h) = h$
IL-4R	$K_{IL-4R} = 1$ $K_{IL-4R}(IL-4^h, SOCS-1^h) = 1$ $K_{IL-4R}(SOCS-1^h) = 1$		$K_{IL-4R}(IL-4^h) = h$
IL-12R	$K_{IL-12R} = 1$ $K_{IL-12R}(IL-12^h, STAT-6^h) = 1$ $K_{IL-12R}(STAT-6^h) = 1$		$K_{IL-12R}(IL-12^h) = h$
IL-18R	$K_{IL-18R} = 1$ $K_{IL-18R}(IL-18^h, STAT-6^h) = 1$ $K_{IL-18R}(STAT-6^h) = 1$		$K_{IL-18R}(IL-18^h) = h$
IFN- $\beta$ R	$K_{IFN-\beta R} = 1$		$K_{IFN-\beta R}(IFN-\beta^h) = h$
STAT-1	$K_{STAT-1} = 1$	$K_{STAT-1}(IFN-\beta R^h) = m$ $K_{STAT-1}(IFN-\gamma R^m) = m$ $K_{STAT-1}(IFN-\gamma R^m, IFN-\beta R^h) = m$	$K_{STAT-1}(IFN-\gamma R^h) = h$ $K_{STAT-1}(IFN-\gamma R^h, IFN-\beta R^h) = h$
STAT-6	$K_{STAT-6} = 1$		$K_{STAT-6}(IL-4R^h) = h$
STAT-4	$K_{STAT-4} = 1$ $K_{STAT-4}(IL-12R^h, GATA-3^h) = 1$ $K_{STAT-4}(GATA-3^h) = 1$		$K_{STAT-4}(IL-12R^h) = h$
IRAK	$K_{IRAK} = 1$		$K_{IRAK}(IL-18R^h) = h$
SOCS-1	$K_{SOCS-1} = 1$		$K_{SOCS-1}(STAT-1^m) = h$ $K_{SOCS-1}(STAT-1^m, T-bet^m) = h$ $K_{SOCS-1}(STAT-1^m, T-bet^h) = h$ $K_{SOCS-1}(STAT-1^h) = h$ $K_{SOCS-1}(STAT-1^h, T-bet^m) = h$ $K_{SOCS-1}(STAT-1^h, T-bet^h) = h$ $K_{SOCS-1}(T-bet^m) = h$ $K_{SOCS-1}(T-bet^h) = h$
GATA-3 (without auto-activation)	$K_{GATA-3} = 1$ $K_{GATA-3}(STAT-6^h, T-bet^m) = 1$ $K_{GATA-3}(STAT-6^h, T-bet^h) = 1$ $K_{GATA-3}(T-bet^m) = 1$ $K_{GATA-3}(T-bet^h) = 1$		$K_{GATA-3}(STAT-6^h) = h$

Table 1 (Continued)

Node	Activation state as a function of the regulatory nodes		
T-bet (without auto-activation in GATA-3)	$K_{T\text{-bet}} = 1$ $K_{T\text{-bet}}(STAT-1^m, GATA-3^h) = 1$ $K_{T\text{-bet}}(STAT-1^h, GATA-3^h) = 1$ $K_{T\text{-bet}}(STAT-1^h, GATA-3^h, T\text{-bet}^m) = 1$ $K_{T\text{-bet}}(STAT-1^h, GATA-3^h, T\text{-bet}^h) = 1$ $K_{T\text{-bet}}(GATA-3^h) = 1$ $K_{T\text{-bet}}(GATA-3^h, T\text{-bet}^m) = 1$ $K_{T\text{-bet}}(GATA-3^h, T\text{-bet}^h) = 1$	$K_{T\text{-bet}}(STAT-1^m) = m$ $K_{T\text{-bet}}(STAT-1^m, GATA-3^h, T\text{-bet}^m) = m$ $K_{T\text{-bet}}(STAT-1^m, T\text{-bet}^m) = m$ $K_{T\text{-bet}}(T\text{-bet}^m) = m$	$K_{T\text{-bet}}(STAT-1^m, GATA-3^h, T\text{-bet}^h) = h$ $K_{T\text{-bet}}(STAT-1^m, T\text{-bet}^h) = h$ $K_{T\text{-bet}}(STAT-1^h) = h$ $K_{T\text{-bet}}(STAT-1^h, T\text{-bet}^m) = h$ $K_{T\text{-bet}}(STAT-1^h, T\text{-bet}^h) = h$ $K_{T\text{-bet}}(T\text{-bet}^h) = h$
GATA-3 (with auto-activation)	$K_{GATA-3} = 1$ $K_{GATA-3}(STAT-6^h, T\text{-bet}^m) = 1$ $K_{GATA-3}(STAT-6^h, T\text{-bet}^h) = 1$ $K_{GATA-3}(STAT-6^h, GATA-3^h, T\text{-bet}^m) = 1$ $K_{GATA-3}(STAT-6^h, GATA-3^h, T\text{-bet}^h) = 1$ $K_{GATA-3}(GATA-3^h, T\text{-bet}^m) = 1$ $K_{GATA-3}(GATA-3^h, T\text{-bet}^h) = 1$ $K_{GATA-3}(T\text{-bet}^m) = 1$ $K_{GATA-3}(T\text{-bet}^h) = 1$		$K_{GATA-3}(STAT-6^h) = h$ $K_{GATA-3}(GATA-3^h) = h$ $K_{GATA-3}(STAT-6^h, GATA-3^h) = h$
T-bet (with auto-activation in GATA-3)	$K_{T\text{-bet}} = 1$ $K_{T\text{-bet}}(STAT-1^m, GATA-3^h) = 1$ $K_{T\text{-bet}}(STAT-1^m, GATA-3^h, T\text{-bet}^m) = 1$ $K_{T\text{-bet}}(STAT-1^m, GATA-3^h, T\text{-bet}^h) = 1$ $K_{T\text{-bet}}(STAT-1^h, GATA-3^h) = 1$ $K_{T\text{-bet}}(STAT-1^h, GATA-3^h, T\text{-bet}^m) = 1$ $K_{T\text{-bet}}(STAT-1^h, GATA-3^h, T\text{-bet}^h) = 1$ $K_{T\text{-bet}}(GATA-3^h) = 1$ $K_{T\text{-bet}}(GATA-3^h, T\text{-bet}^m) = 1$ $K_{T\text{-bet}}(GATA-3^h, T\text{-bet}^h) = 1$	$K_{T\text{-bet}}(STAT-1^m) = m$ $K_{T\text{-bet}}(STAT-1^m, T\text{-bet}^m) = m$ $K_{T\text{-bet}}(T\text{-bet}^m) = m$	$K_{T\text{-bet}}(STAT-1^m, T\text{-bet}^h) = h$ $K_{T\text{-bet}}(STAT-1^h) = h$ $K_{T\text{-bet}}(STAT-1^h, T\text{-bet}^m) = h$ $K_{T\text{-bet}}(STAT-1^h, T\text{-bet}^h) = h$ $K_{T\text{-bet}}(T\text{-bet}^h) = h$

The logical rule defining the level of activity of each node is a function of the levels of its regulators and is specified in terms of logical parameters (K's). The subindex following the K refers to the name of the node, whereas the current operating regulators (inputs) are written inside the parentheses. Finally, superindices make explicit the corresponding regulatory level of a given input. For example,  $K_{IL-4}$  stands for is the response of IL-4 when no activations and no inhibitions act upon it. Similarly,  $K_{IL-4}(STAT-1^h)$  represents the response of IL-4 when STAT-1 is in its “high” level; while  $K_{IL-4}(STAT-1^m, GATA-3^h)$  is the response of IL-4 to the simultaneous presence of STAT-1 at its “medium” level and GATA-3 at its “high” level. GATA-3 and T-bet have two alternative sets of values, which correspond to the two variants of the model, depending on the presence or the absence of the GATA-3 auto-activation.

4. High levels of IL-4, IL-4R, STAT-6 and GATA-3 (all other nodes at low levels).

Each attractor can be reached from other states, thus forming a basin of attraction. These basins are the four regions of the state space divided by the separatrices, which are created by the eight functional positive loops. Given the high dimensionality of the model, it is impossible to represent graphically its entire state space. Nevertheless, for illustration purposes Fig. 3 schematically represents a subregion of the state space to show the role of three functional circuits in creating the four basins of attraction, and the fixed-point attractors inside them. These four attractors have a clear biological interpretation. The first corresponds to the state observed in Th0 cells, which do not produce any of the cytokines included in the network. The second and third attractors are closely related, and represent different subpopula-

tions of Th1 cells. The difference between them lies in the levels of activation of IFN- $\gamma$  and T-bet, leading to different levels of IFN- $\gamma$  secretion. The patterns of activity in these attractors are qualitatively consistent with the experimental data for Th1 cells (Tau et al., 2000; Egwuagu et al., 2002). Finally, the fourth attractor, where only IL-4, IL-4R, STAT-6 and GATA-3 are active, represents the state of Th2 cells (Cousins et al., 2002; Seki et al., 2002).

As mentioned above, the Th model analysis predicts the existence of two Th1 attractors, differing in the level of IFN- $\gamma$  activity. However, in both cases, the activation of IFN- $\gamma$ R is at its medium level. There is experimental evidence for this moderate activity of the IFN- $\gamma$  receptor. Th1 cells respond to IFN- $\gamma$  via IFN- $\gamma$ R, but high level of expression of this receptor can lead to cell death in human T lymphocytes. However, they avoid IFN- $\gamma$ -induced apoptosis by diminishing, without

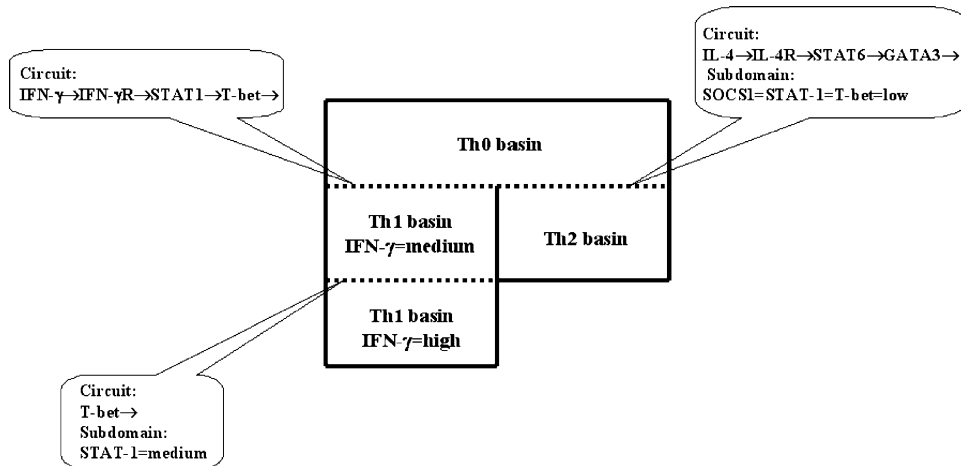

Fig. 3. The state space of the Th model contains four basins of attraction. This figure represents the subdomain of the state space where the following eight variables are in their ‘low’ state: IL-12, IL-18, IFN- $\beta$ , IL-12R, IL-18R, IFN- $\beta$ R, STAT-4, and IRAK. In this subdomain of the state space, it is possible to depict the separatrices (dotted lines) generated by three functional circuits, and the four basins of attraction present in the Th model.

totally eliminating, the number of IFN- $\gamma$ R molecules at the cell surface (Novelli et al., 1997; Rigamonti et al., 2000; Skrenta et al., 2000), thereby reducing the strength of the IFN- $\gamma$  signal. The Th model reflects this signal attenuation; when the network is in either of the two Th1 attractors, the activation of the IFN- $\gamma$ R node reaches only a medium level of activation, even when the IFN- $\gamma$  signal is at its activation peak.

In the model presented here, the attractors correspond to the Th0, Th1 and Th2 cell types. Consequently, the differentiation process itself can be represented by the transition of the system from one attractor to another. For this effect to take place, it is sufficient to give the network a stimulus that displaces the system from one basin of attraction to another. Once the system is in a new basin of attraction, it will spontaneously reach the corresponding attractor. However, the dynamical rules in Table 1 are insufficient to specify unique dynamical trajectories. For example, if IL-12 and IL-18 are active in the model, time delays need to be considered to determine whether IL-12R becomes active before, after, or at the same time as IL-18R. Nonetheless, it is instructive to explore if the dynamical rules permit the existence of a handful of trajectories that are biologically meaningful. Generally speaking, a typical signaling cascade starts with the activation of a membrane receptor, due to the binding of its agonist, promoting the activation of a series of transduction molecules, which eventually affect the expression of a set of transcription factors. Fig. 4 represents trajectories that are consistent with the experimental knowledge, as well as with the dynamical rules shown in Table 1. Starting from the Th0 attractor, it is possible to simulate a stimulation of the system by IFN-

$\gamma$ , IL-4, or a mixture of IL-12 and IL-18. Experimentally, such treatments result in differentiations towards Th1, Th2, and Th1 with high levels of IFN- $\gamma$ , respectively (Kanakaraj et al., 1999; Murphy and Reiner, 2002).

Previously published models incorporate a GATA-3 auto-activatory feedback loop to ensure bistability (Yates et al., 2004; Mariani et al., 2004). By contrast, the present variant of the Th model does not incorporate such feedback loop; and yet GATA-3 presents bistability. The reason is that GATA-3 is involved in three functional positive circuits (numbers 7, 16, and 18 in Supplementary Table 1). Of these three, the circuit  $IL-4 \rightarrow IL-4R \rightarrow STAT6 \rightarrow GATA-3 \rightarrow$  plays the same role as a direct self-activation of GATA-3 in the studies mentioned above. This is not surprising given that the logical analysis shows that the dynamical behavior of a circuit depends on its sign, not on its length. The previous four-element positive feedback loop considered here can be viewed as a refinement of the GATA-3 auto-activation presented in previously published models.

## 2.2. Mutant simulations

Further insight into the Th regulatory network can be obtained from the simulation of single or multiple null mutations, over-activations, or any combination thereof. Since the number of possible modifications is very high, the attractors obtained for only a handful of representative mutants are presented in Table 2, and further discussed in the following paragraphs. Additionally, Supplementary Table 2 contains the attractors of all possible single positive and negative mutants. The biological interpretation of these variants of the Th

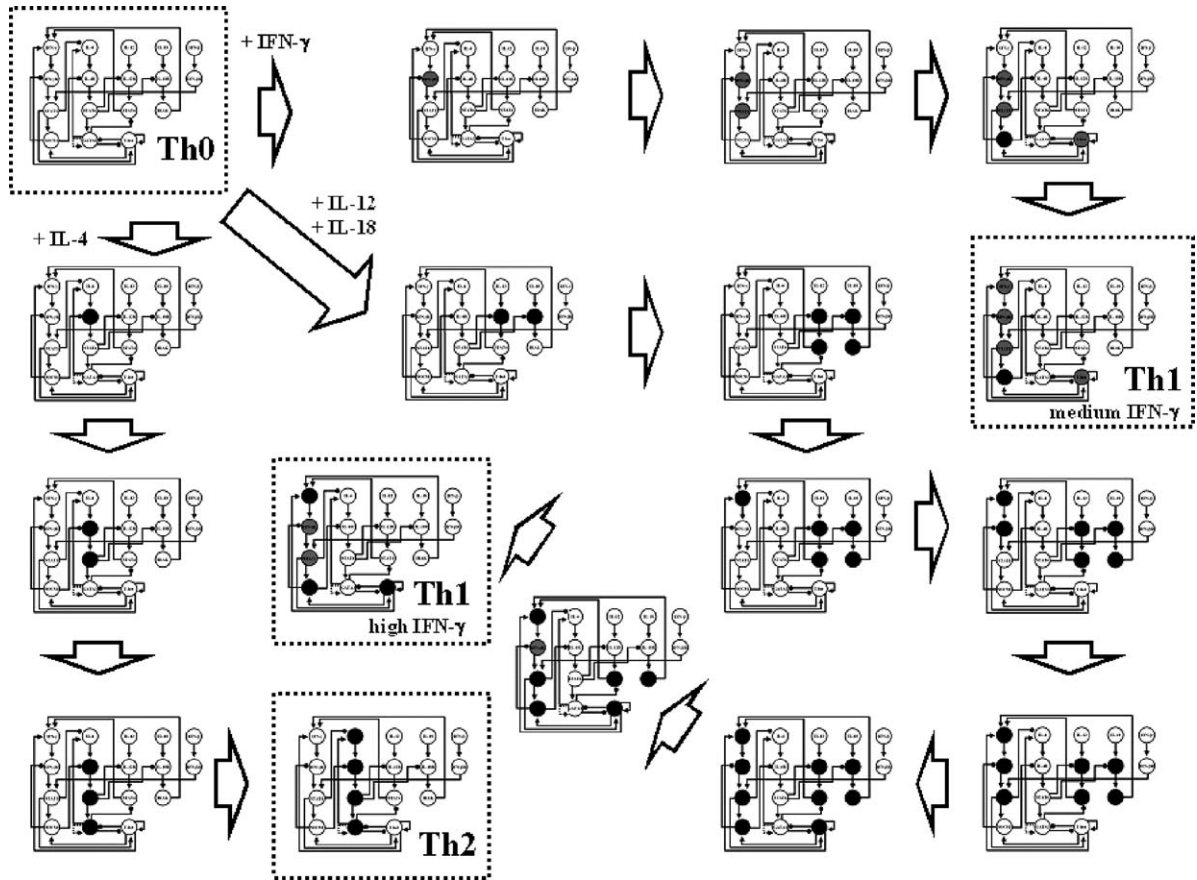

Fig. 4. Some possible transitions of the Th model, consistent with the differentiation of Th cells. The model contains only four attractors (dotted squares); hence any other activation state is transitory and will eventually lead to one of the attractors. There are three trajectories with a clear biological counterpart. Starting from the Th0 state, the activation of the IL-4R node, which simulates the effect of adding IL-4 to the extracellular medium, leads to the Th2 attractor. In a similar way, the activation of IFN- $\gamma$ R simulates the effect of adding IFN- $\gamma$  to Th0 cells, thus creating a signal that leads the system to one of the Th1 attractors. Finally, the simulation of addition of IL-12 and IL-18 simultaneously, is mimicked by the activation of IL-12R and IL-18R, which leads the system to the Th1 attractor with high IFN- $\gamma$  and T-bet levels. White, gray and black circles represent nodes with low, medium and high levels of functionality, respectively.

model representing mutants may vary depending on the experimental set-up. For example, the T-bet<sup>+</sup> variant represents the expression of T-bet under the control of a constitutive promoter inside the Th cells. In contrast, IL-12<sup>+</sup>, IL-18<sup>+</sup> and IFN- $\beta$ <sup>+</sup> represent Th cells cultured in media containing high levels of IL-12, IL-18 or IFN- $\beta$ , since Th cells do not produce these molecules.

IL-12 has been widely recognized as a key cytokine in the activation of the IFN- $\gamma$  pathway, and therefore in the development of Th1 cells. However, there is evidence (Szabo et al., 2003) that the IL-12 pathway may not be required to initiate a Th1 response in vivo, leading even to the proposition that the human IL-12 signaling pathway is entirely redundant (Fieschi and Casanova, 2003). The Th model captures these apparently contradicting features. In the IL-12<sup>+</sup> mutant, the Th0 attractor is lost

(Table 2), meaning that high levels of IL-12 function as a differentiation signal in the model, because it pushes the system out of the basal state. However, in the case of IL-12<sup>-</sup>, IL-12R<sup>-</sup>, and IL-12<sup>-</sup>/IL-12R<sup>-</sup> single and double mutants, the system keeps exactly the same four attractors as in the wild-type case (see Supplementary Table 2), implying that the IL-12 pathway is dispensable in the differentiation process.

Continuing with the IL-12<sup>+</sup> case, note that the Th0 attractor disappears, but the Th2 attractor remains. This might seem wrong with regard to the known importance of IL-12 in the polarization of cells towards the Th1 phenotype. But there is experimental evidence to support this prediction. Normally, Th2 cells lack the  $\beta$ 2 subunit of the IL-12R, which make them unresponsive to an IL-12 treatment. However, cells have been transfected with

Table 2  
Attractors of various mutants of the Th model

	Steady states of activation																	
	IFN- $\gamma$	IL-4	IL-12	IL-18	IFN- $\beta$	IFN- $\gamma$ R	IL-4R	IL-12R	IL-18R	IFN- $\beta$ R	STAT-1	STAT-6	STAT-4	IRAK	SOCS-1	GATA-3	T-bet	
Wild type	Low	Low	Low	Low	Low	Low	Low	Low	Low	Low	Low	Low	Low	Low	Low	Low	Low	
	High	Low	Low	Low	Low	Medium	Low	Low	Low	Low	Medium	Low	Low	Low	Low	High	Low	High
	Medium	Low	Low	Low	Low	Medium	Low	Low	Low	Low	Medium	Low	Low	Low	Low	High	Low	Medium
	Low	High	Low	Low	Low	Low	High	Low	Low	Low	Low	High	Low	Low	Low	Low	High	Low
IFN- $\gamma^-$	Low	Low	Low	Low	Low	Low	Low	Low	Low	Low	Low	Low	Low	Low	Low	Low	Low	Low
	Low	Low	Low	Low	Low	Low	Low	Low	Low	Low	Low	Low	Low	Low	Low	High	Low	Medium
	Low	Low	Low	Low	Low	Low	Low	Low	Low	Low	Low	Low	Low	Low	Low	High	Low	High
	Low	High	Low	Low	Low	Low	High	Low	Low	Low	Low	High	Low	Low	Low	Low	High	Low
IFN- $\gamma$ R $^-$	Low	Low	Low	Low	Low	Low	Low	Low	Low	Low	Low	Low	Low	Low	Low	Low	Low	Low
	Medium	Low	Low	Low	Low	Low	Low	Low	Low	Low	Low	Low	Low	Low	Low	High	Low	Medium
	High	Low	Low	Low	Low	Low	Low	Low	Low	Low	Low	Low	Low	Low	Low	High	Low	High
	Low	High	Low	Low	Low	Low	High	Low	Low	Low	Low	High	Low	Low	Low	Low	High	Low
IL-12 $^+$	Medium	Low	High	Low	Low	Medium	Low	High	Low	Low	Medium	Low	High	Low	High	Low	Medium	
	High	Low	High	Low	Low	Medium	Low	High	Low	Low	Medium	Low	High	Low	High	Low	High	
	Low	High	High	Low	Low	Low	High	Low	Low	Low	Low	High	Low	Low	Low	High	Low	
IL-18 $^+$	Low	Low	Low	High	Low	Low	Low	Low	High	Low	Low	Low	Low	High	Low	Low	Low	Low
	Medium	Low	Low	High	Low	Medium	Low	Low	High	Low	Medium	Low	Low	High	High	Low	Medium	
	High	Low	Low	High	Low	Medium	Low	Low	High	Low	Medium	Low	Low	High	High	Low	High	
	Low	High	Low	High	Low	Low	High	Low	Low	Low	Low	High	Low	Low	Low	High	Low	
IL-12 $^+$ /IL-18 $^+$	High	Low	High	High	Low	Medium	Low	High	High	Low	Medium	Low	High	High	High	Low	High	
	High	Low	High	High	Low	Medium	Low	High	High	Low	Medium	Low	High	High	High	Low	Medium	
	Low	High	High	High	Low	Low	High	Low	Low	Low	Low	High	Low	Low	Low	High	Low	
GATA-3 $^+$	Low	High	Low	Low	Low	Low	High	Low	Low	Low	Low	High	Low	Low	Low	High	Low	Low
	Medium	Low	Low	Low	Low	Medium	Low	Low	Low	Low	Medium	Low	Low	Low	High	High	Medium	
	High	Low	Low	Low	Low	Medium	Low	Low	Low	Low	Medium	Low	Low	Low	High	High	High	

the missing molecule, and then incubated with IL-12 (Heat et al., 2000), thus rendering IL-12R continuously active. Interestingly, under such treatment, committed Th2 cells do not produce IFN- $\gamma$  or reduce the production of IL-4, thus matching the Th2 attractor. Hence, once the system is in the Th2 basin of attraction, even high levels of IL-12, IL-12R and STAT-4 are not sufficient to take the system into another basin of attraction.

The Th model also brings some insight into the origin of the unexpected phenotypes of IFN- $\gamma^-$  and IFN- $\gamma R^-$  loss-of-function mutants. IFN- $\gamma$  and IFN- $\gamma R$  belong to the same positive feedback loop, so one might expect that eliminating one or the other would result in the same phenotype. But, as shown in Table 2, the attractors of these mutants differ in the level of activation of IFN- $\gamma$ . This difference has also been observed experimentally; IFN- $\gamma^-$  mutants do not produce IFN- $\gamma$  (Tang et al., 1998) as expected. But IFN- $\gamma R^-$  mutants do produce IFN- $\gamma$  (Diehl et al., 2000); and at first sight it is not obvious why. Just by looking at the topology of the network, it is clear that the elimination of either IFN- $\gamma$  or IFN- $\gamma R$  breaks the IFN- $\gamma \rightarrow$  IFN- $\gamma R \rightarrow$  STAT1  $\rightarrow$  T-bet  $\rightarrow$  circuit. However, as the T-bet  $\rightarrow$  circuit remains functional (see Supplementary Table 1), any transient signal capable of activating T-bet (via STAT-1, for example) will result in a self-sustained stable activation of T-bet, which in turn will activate IFN- $\gamma$  if it is intact, even in the absence of IFN- $\gamma R$ .

Besides mutations, the inclusion of some nodes with more than two states of activation allows to account for the phenomenon of potentiation. Specifically, IL-18 is a very poor inducer of IFN- $\gamma$  on its own, but is a potent inducer in combination with IL-12 (Kanakaraj et al., 1999). In Table 1,  $\mathbf{K}_{\text{IFN-}\gamma(\text{IRAK}^h)}=1$  means that if IRAK is at its high level (due to the presence of IL-18), the IFN- $\gamma$  node will remain in its low level. Then,  $\mathbf{K}_{\text{IFN-}\gamma(\text{STAT-4}^h)}=m$  indicates that IFN- $\gamma$  will turn to its medium level in response to an activation from STAT-4, which is part of the IL-12 pathway. Finally,  $\mathbf{K}_{\text{IFN-}\gamma(\text{IRAK}^h, \text{STAT-4}^h)}=h$  means that the IFN- $\gamma$  node reaches its high level when both STAT-4 and IRAK are present. These logical rules result in the generation of alternative attractors for the different mutants. In the case of IL-18 $^+$ , the system can reach four attractors, similar to those of the wild-type, but with the extra activation of IL-18, IL-18R, and IRAK (Table 2). Thus, the over-expression of the IL-18 pathway does not force the system to behave differently from the wild-type. This situation contrasts with the loss of the Th0 attractor in IL-12 $^+$  cells. Finally, a combined IL-12 $^+$ /IL-18 $^+$  over-activation also leads to the loss the Th0 attractor, but IFN- $\gamma$  is then highly expressed. Therefore, according to

the Th model, the simultaneous action of IL-12 and IL-18 forces IFN- $\gamma$  to reach its activation peak.

The previous paragraphs provide some examples for the interpretation of the number and nature of the attractors for different perturbations. The Th model can be used to simulate many other situations, by fixing the level of activation of one node, or of a combination of nodes, at some specific level(s). Supplementary Table 2 includes the attractors found for 35 variants of the Th model, namely: the wild-type case, 17 single-node inactivations, and 17 single-node constitutive activations. In total, all these variants encompass 110 attractors. Many of these attractors represent predictions of the model, as the corresponding situations have not yet been thoroughly characterized.

### 2.3. Special case: the mouse

As mentioned previously, this study is based on experimental data originating from both human and mouse. However, it is instructive to explicitly consider the situation in the mouse, which presents two unique features: first, the possible existence of a GATA-3 auto-activatory circuit (Zhou and Ouyang, 2003); and second, the inability of GATA-3 to sustain its expression when T-bet is present (Smits et al., 2001). These two characteristics can be included in the Th model by using an alternative set of logical rules for GATA-3 and T-bet (last two rows of Table 1). Specifically,  $\mathbf{K}_{\text{GATA-3}(\text{GATA-3}^h)}=h$  indicates that GATA-3 is able to activate itself, implying the existence of a feedback loop. And since STAT-6 acts positively on GATA-3, then a combination of GATA-3 and STAT-6 should also activate GATA-3; represented by  $\mathbf{K}_{\text{GATA-3}(\text{STAT-6}^h, \text{GATA-3}^h)}=h$ . For its part, T-bet exerts a strong inhibition GATA-3 thus making all other parameters of  $\mathbf{K}_{\text{GATA-3}}$  equal to 'low'. Finally, since GATA-3 is not strong enough to inhibit T-bet, any  $\mathbf{K}_{\text{T-bet}}$  parameter containing GATA-3 is set to 'low'.

The resulting attractors are identical to those obtained in the human case; that is, four attractors representing the Th0, Th2 and two Th1 patterns of activation. The differences just appear in the domains of functionality for some of the circuits in the model. Specifically, the alternative rules generate one new functional circuit (number 23 in Supplementary Table 3), cause the loss of functionality of one circuit (number 7), render four circuits functional (numbers 8, 12, 15, and 17), and affect the functionality domains of four other circuits (numbers 9, 11, 18, and 19). Despite these changes, it is important to stress that, as in the case of the human variant, the logical analysis reveals that none of the negative feedback loops are functional. Hence, the asymptotic dynamical behav-

ior of the Th model is not significantly modified by the alternative rules used to best represent the information observed in mouse cells.

### 3. Conclusions

The differentiation process of T lymphocytes offers multiple advantages from the modeling point of view: it is a system that has been amply studied experimentally, many of the key molecular players are known, and their responses to many signals have been evaluated. As a result, models for different aspects of the physiology of T lymphocytes have been published, which address processes involved in the activation (Kaufman et al., 1999; Sarkar and Franza, 2004), or the determination of cellular fate (Bergmann and van Hemmen, 2001; Bergmann et al., 2002). Such studies, however, do not incorporate the intracellular molecular network enabling the cells to acquire different physiological states or fates, except for the inclusion of a small number of key transcription factors. Despite the lack of comprehensive molecular data, previous models provide information on the kind of minimal model that might still capture the essence of Th cell differentiation. Specifically, a model with two mutually inhibitory nodes, each with a positive feedback loop, suffices to create a system with three steady stable states representing the main differentiated T helper cell types (Kaufman et al., 1985; Yates et al., 2004; Mariani et al., 2004). Since T-bet and GATA-3 inhibit each other and are involved in direct and indirect positive feedback loops, these two molecules constitute the central feature of models of T helper differentiation. The present study is aimed at complementing such minimal models, by providing more comprehensive data on the nature of the intracellular regulatory network of Th cells. In this aspect, the present regulatory network is an extension, or a refinement of the minimal models, as explained for the case of GATA-3 positive feedback. However, there is valuable information that can be gained by increasing the molecular detail incorporated to the network. Particularly, a more biologically complete network permits the delineation of the effect of single and multiple null-and/or constitutive-expression mutants on the differentiation of Th cells, as shown in [Supplementary Table 2](#).

This study introduced a network model for the control of the differentiation process of T helper cells, whose topology was deduced from published molecular data. The network was modeled as a discrete system, and its asymptotic behavior was studied with the aid of the generalized logical formalism. The analysis permitted the identification of all the stable states of the system. The Th model has only four attractors, which clearly corre-

spond to the patterns of activation observed in wild-type Th cells. Moreover, the model can be modified so as to describe the asymptotic patterns of expression of null mutants, as well as constitutive-expression variants. This capacity of the model to simulate mutants helps to interpret some apparently contradictory phenotypes. Specifically, an explanation has been provided for the apparent redundancy of the IL-12 pathway, despite its recognized importance in the differentiation of Th0 into Th1 cells. It also helps in understanding why the phenotypes of null mutations in IFN- $\gamma$  and IFN- $\gamma$ R are different. This capacity of describing mutants is an important feature of the model. Although many genetically modified Th cells have been studied experimentally, the molecular characterization of these cells is usually restricted to only a few molecules of interest, typically IFN- $\gamma$ , IL-4, GATA-3 and T-bet. Now, the Th model makes it possible to explore the effects of multiple null mutations, or combinations of mutations and over-expressions.

The present version of the Th network contains 17 nodes. Clearly, many more molecules are involved in the differentiation of T helper cells. For example, the T cell receptor (TCR) and IL-10 pathways are known to bias the system towards the Th1 or Th2 cellular fate. The incorporation of these molecules should result in a more accurate description of the differentiation process. Despite its limited number of nodes, the present Th model is able to reproduce the basic wild type cellular states (Th0, Th1, and Th2), and a large number of mutant phenotypes.

The logical approach that was used for this study made it possible to find all the attractors in the different variants of the Th model. However, to represent the selection a specific trajectory, it is necessary to incorporate time delays into the model, so as to determine the precise order of response for each node in the network. As information about such delays is not yet available, they were omitted so as to keep the number of suppositions to a minimum. In any case, the resulting focus on stable states has the advantage to provide an easy way for experimental verification. Indeed, experimental studies rely heavily on cell cultures and measurements of secreted or internally expressed molecules after long periods of incubation. Such experimental conditions (see, for example, Fig. 7 in Cousins et al., 2002) can be directly associated with the stable patterns of expression as represented by an attractor.

The prospects for the growth of the Th model involve addressing three main areas of simplification used for its elaboration. First, the model does not explicitly incorporate molecular mechanisms. Cells carry out activations and inhibitions in many different ways, e.g. through

chromatin remodeling, protein degradation, phosphorylation, transcriptional regulation, etc. The eventual inclusion of such mechanisms into the model may help to understand the relative importance, temporality, and reversibility of the different regulatory interactions. Secondly, the logical model presented here could be transposed into a continuous formalism (using ODEs) in order to generate quantitative predictions, which could be used to make a more accurate comparison with experimental data. Finally, the model does not deal with cell populations. In vivo and in vitro experiments involve multiple cells and usually also multiple cell types, and cellular communication is definitely a key to maintain pools of differentiated and undifferentiated cells, as well as memory cells. Hence, it is clearly necessary to expand the Th model, or to integrate it with other models, so as to be able to describe cell populations to make a more realistic description of the differentiation of T lymphocytes.

### Acknowledgements

The author would like to thank Ioannis Xenarios, Massimo de Francesco, Yolande Chvatchko, Anne Corbaz, Ram Selvaraju, Georg Feger, Denis Thieffry, and two anonymous referees for their invaluable help and insights.

### Appendix A. Supplementary data

Supplementary data associated with this article can be found, in the online version, at [doi:10.1016/j.biosystems.2005.10.004](https://doi.org/10.1016/j.biosystems.2005.10.004).

### References

- Afkarian, M., Sedy, J.R., Yang, J., Jacobson, N.G., Cereb, N., Yang, S.Y., Murphy, T.L., Murphy, K.M., 2002. T-bet is a STAT1-induced regulator of IL-12R expression in naive CD4<sup>+</sup> T cells. *Nat. Immunol.* 3, 549–557.
- Agnello, D., Lankford, C.S.R., Bream, J., Morinobu, A., Gadina, M., O’Shea, J., Frucht, D.M., 2003. Cytokines and transcription factors that regulate T helper cell differentiation: new players and new insights. *J. Clin. Immunol.* 23, 147–161.
- Akira, S., 2000. The role of IL-18 in innate immunity. *Curr. Opin. Immunol.* 12, 59–63.
- Bergmann, C., van Hemmen, J.L., 2001. Th1 or Th1: how an appropriate T helper response can be made. *Bull. Math. Biol.* 63, 405–430.
- Bergmann, C., van Hemmen, J.L., Segel, L.A., 2002. How instruction and feedback can select the appropriate T helper response. *Bull. Math. Biol.* 64, 425–446.
- Bernabei, P., Coccia, E.M., Rigamonti, L., Bosticardo, M., Forni, G., Pestka, S., Krause, C.D., Battistini, A., Novelli, F., 2001. Interferon- $\gamma$  receptor 2 expression as the deciding factor in human T, B, and myeloid cell proliferation or death. *J. Leukoc. Biol.* 70, 950–960.
- Chang, J.T., Segal, B.M., Nakanishi, K., Okamura, H., Shevach, E.M., 2000. The costimulatory effect of IL-18 on the induction of antigen-specific IFN- $\gamma$  production by resting T cells is IL-12 dependent and is mediated by up-regulation of the IL-12 receptor beta2 subunit. *Eur. J. Immunol.* 30, 1113–1119.
- Chen, X.P., Losman, J.A., Rothman, P., 2000. SOCS proteins, regulators of intracellular signaling. *Immunity* 13, 287–290.
- Cousins, D.J., Lee, T.H., Staynov, D.Z., 2002. Cytokine coexpression during human Th1/Th2 cell differentiation: direct evidence for coordinated expression of Th2 cytokines. *J. Immunol.* 169, 2498–2506.
- Diehl, S., Anguita, J., Hoffmeyer, A., Zapton, T., Ihle, J.N., Fikrig, E., Rincón, M., 2000. Inhibition of Th1 differentiation by IL-6 is mediated by SOCS1. *Immunity* 13, 805–815.
- Egwuagu, C.E., Yu, C.R., Zhang, M., Mahdi, R.M., Kim, S.J., Gery, I., 2002. Suppressors of cytokine signaling proteins are differentially expressed in Th1 and Th2 cells: implications for the Th cell lineage commitment and maintenance. *J. Immunol.* 168, 3181–3187.
- Elser, B., Lohoff, M., Kock, S., Giaisi, M., Kirchhoff, S., Krammer, P.H., Li-Weber, M., 2002. IFN- $\gamma$  represses IL-4 expression via IRF-1 and IRF-2. *Immunity* 17, 703–712.
- Fieschi, C., Casanova, J.L., 2003. The role of interleukin-12 in human infectious diseases: only a faint signature. *Eur. J. Immunol.* 33, 1461–1464.
- Glimcher, L.H., Murphy, K.M., 2000. Lineage commitment in the immune system: the T helper lymphocyte grows up. *Genes Dev.* 14, 1693–1711.
- Goodbourn, S., Didcock, L., Randal, R.E., 2000. Interferons: cell signalling, immune modulation, antiviral responses and virus countermeasures. *J. Gen. Virol.* 81, 2341–2364.
- Hamalainen, H., Zhou, H., Chou, W., Hashizume, H., Heller, R., Lahesmaa, R., 2001. Distinct gene expression profiles of human type 1 and type 2 T helper cells. *Genome Biol.* 2, research 0022.1–0022.11.
- Heat, V.L., Showe, L., Crain, C., Barrat, F.J., Trinchieri, G., O’Garra, A.O., 2000. Cutting edge: ectopic expression of the IL-12 receptor- $\beta$ 2 in developing and committed Th2 cells does not affect the production of IL-4 or induce the production of IFN- $\gamma$ . *J. Immunol.* 164, 2861–2865.
- Kanakaraj, P., Ngo, K., Wu, Y., Angulo, A., Ghazal, P., Harris, C.A., Siekierka, J.J., Peterson, P.A., Fung-Leung, W.P., 1999. Defective interleukin (IL)-18-mediated natural killer and T helper cell type 1 response in IL-1 receptor-associated kinase (IRAK)-deficient mice. *J. Exp. Med.* 189, 1129–1138.
- Kaufman, M., Urbain, J., Thomas, R., 1985. Towards a logical analysis of the immune response. *J. Theor. Biol.* 114, 527–561.
- Kaufman, M., Andris, F., Leo, O., 1999. A logical analysis of T cell activation and anergy. *Proc. Natl. Acad. Sci. U.S.A.* 96, 3894–3899.
- Kotenko, S.V., Pestka, S., 2000. Jak-Stat signal transduction pathway through the eyes of cytokine class II receptor complexes. *Oncogene* 19, 2557–2565.
- Lighvani, A.A., Frucht, D.M., Jankovic, D., Yamane, H., Aliberti, J., Hissong, B.D., Nguyen, B.V., Gadina, M., Sher, A., Paul, W.E., O’Shea, J.J., 2001. T-bet is rapidly induced by interferon- $\gamma$  in lymphoid and myeloid cells. *Proc. Natl. Acad. Sci. U.S.A.* 98, 15137–15142.
- Losman, J.A., Chen, X.P., Hilton, D., Rothman, P., 1999. Cutting edge: SOCS-1 is a potent inhibitor of IL-4 signal transduction. *J. Immunol.* 162, 3770–3774.
- Mariani, L., Löhning, M., Radbruch, A., Höfer, T., 2004. Transcriptional control networks of cell differentiation: insights from helper T lymphocytes. *Prog. Biophys. Mol. Biol.* 86, 45–76.

- Mendoza, L., Thieffry, D., Alvarez-Buylla, E.R., 1999. Genetic control of flower morphogenesis in *Arabidopsis thaliana*: a logical analysis. *Bioinformatics* 15, 593–606.
- Moriggl, R., Kristofic, C., Kinzel, B., Volarevic, S., Groner, B., Brinkmann, V., 1998. Activation of STAT proteins and cytokine genes in human Th1 and Th2 cells generated in the absence of IL-12 and IL-4. *J. Immunol.* 160, 3385–3392.
- Mullen, A.C., High, F.A., Hutchins, A.S., Lee, H.W., Villarino, A.V., Livingston, D.M., Kung, A.L., Cereb, N., Yao, T.P., Yang, S.Y., Reiner, S.L., 2001. Role of T-bet in commitment of Th1 cells before IL-12-dependent selection. *Science* 292, 1907–1910.
- Murphy, K.M., Reiner, S.L., 2002. The lineage decisions on helper T cells. *Nat. Rev. Immunol.* 2, 933–944.
- Nelms, K., Keegan, A.D., Zamorano, J., Ryan, J.J., Paul, W.E., 1999. The IL-4 receptor: signaling mechanisms and biologic functions. *Annu. Rev. Immunol.* 17, 701–738.
- Novelli, F., D'Elios, M.M., Bernabei, P., Ozmen, L., Rigamonti, L., Almerigogna, F., Forni, G., Del Prete, G., 1997. Expression and role in apoptosis of the  $\alpha$ - and  $\beta$ -chains of the IFN- $\gamma$  receptor in human Th1 and Th2 clones. *J. Immunol.* 159, 206–213.
- Ohmori, Y., Hamilton, T.A., 1997. IL-4-induced STAT6 suppresses IFN- $\gamma$ -stimulated STAT1-dependent transcription in mouse macrophages. *J. Immunol.* 159, 5474–5482.
- Ouyang, W., Löhning, M., Gao, Z., Assenmacher, M., Ranganath, S., Radbruch, A., Murphy, K.M., 2000. Stat6-independent GATA-3 autoactivation directs IL-4-independent Th2 development and commitment. *Immunity* 12, 27–37.
- Ranganath, S., Murphy, K.M., 2001. Structure and specificity of GATA proteins in Th2 development. *Mol. Cell. Biol.* 21, 2716–2725.
- Remy, E., Ruet, P., Mendoza, L., Thieffry, D., Chauviya, C., in press. From logical regulatory graphs to standard Petri nets: dynamical roles and functionality of feedback circuits. *Trans. Comput. Systems Biol.*
- Rigamonti, L., Ariotti, S., Losana, G., Gradini, R., Russo, M.A., Jouanguy, E., Casanova, J.L., Forni, G., Novelli, F., 2000. Surface expression of the IFN- $\gamma$ R2 chain is regulated by intracellular trafficking in human T lymphocytes. *J. Immunol.* 164, 201–207.
- Saito, H., Morita, Y., Fujimoto, M., Narazaki, M., Naka, T., Kishimoto, T., 2000. IFN regulatory factor-1-mediated transcriptional activation of mouse STAT-induced STAT inhibitor-1 gene promoter by IFN- $\gamma$ . *J. Immunol.* 164, 5833–5843.
- Sánchez, L., Thieffry, D., 2003. Segmenting the fly embryo: a logical analysis of the pair-rule cross-regulatory module. *J. Theor. Biol.* 224, 517–537.
- Sarkar, A., Franza, B.R., 2004. A logical analysis of the process of T cell activation: different consequences depending on the state of CD28 engagement. *J. Theor. Biol.* 226, 455–466.
- Seki, Y., Hayashi, K., Matsumoto, A., Seki, N., Tsukada, J., Ransom, J., Naka, T., Kishimoto, T., Yoshimura, A., Kubo, M., 2002. Expression of the suppressor of cytokine signaling-5 (SOCS5) negatively regulates IL-4-dependent STAT6 activation and Th2 differentiation. *Proc. Natl. Acad. Sci. U.S.A.* 99, 13003–13008.
- Skrenta, H., Yang, Y., Pestka, S., Fathman, C.G., 2000. Ligand-independent down-regulation of IFN- $\gamma$  receptor 1 following TCR engagement. *J. Immunol.* 164, 3506–3511.
- Smeltz, R.B., Chen, J., Hu-Li, J., Shevach, E.M., 2001. Regulation of interleukin (IL)-18 receptor  $\alpha$  chain expression on CD4+ T cells during T helper (Th)1/Th2 differentiation: critical downregulatory role of IL-4. *J. Exp. Med.* 194, 143–153.
- Smits, H.H., van Rietschoten, J.G., Hilkens, C.M., Sayilir, R., Stiekema, F., Kapsenberg, M.L., Wierenga, E.A., 2001. IL-12-induced reversal of human Th2 cells is accompanied by full restoration of IL-12 responsiveness and loss of GATA-3 expression. *Eur. J. Immunol.* 31, 1055–1065.
- Swain, S.L., 2001. Interleukin 18: tipping the balance towards a T helper cell 1 response. *J. Exp. Med.* 194, F11–F14.
- Szabo, S.J., Jacobson, N.G., Dighe, A.S., Gubler, U., Murphy, K.M., 1995. Developmental commitment to the Th2 lineage by extinction of IL-12 signaling. *Immunity* 2, 665–675.
- Szabo, S.J., Dighe, A.S., Gubler, U., Murphy, K.M., 1997. Regulation of the interleukin (IL)-12R  $\beta$ 2 subunit expression in developing T helper 1 (Th1) and Th2 cells. *J. Exp. Med.* 185, 817–824.
- Szabo, S.J., Kim, S.T., Costa, G.L., Zhang, X., Fathman, C.G., Glimcher, L.H., 2000. A novel transcription factor, T-bet, directs Th1 lineage commitment. *Cell* 100, 655–669.
- Szabo, S.J., Sullivan, B.M., Peng, S.L., Glimcher, L.H., 2003. Molecular mechanisms regulating Th1 immune responses. *Annu. Rev. Immunol.* 21, 713–758.
- Tang, H., Sharp, G.C., Peterson, K.P., Braley-Mullen, H., 1998. IFN- $\gamma$ -deficient mice develop severe granulomatous experimental autoimmune thyroiditis with eosinophil infiltration in thyroids. *J. Immunol.* 160, 5105–5112.
- Tau, G.Z., von der Weid, T., Lu, B., Cowan, S., Kvatyuk, M., Pernis, A., Cattoretti, G., Braunstein, N.S., Coffman, R.L., Rothman, P.B., 2000. Interferon  $\gamma$  signaling alters the function of T helper type 1 cells. *J. Exp. Med.* 192, 977–986.
- Thieffry, D., Sánchez, L., 2002. Alternative epigenetic states understood in terms of specific regulatory structures. *Ann. N.Y. Acad. Sci.* 981, 135–153.
- Thierfelder, W.E., van Deursen, J.M., Yamamoto, K., Tripp, R.A., Sarawar, S.R., Carson, R.T., Sangster, M.Y., Vignali, D.A., Doherty, P.C., Grosveld, G.C., Ihle, J.N., 1996. Requirement for Stat4 in interleukin-12-mediated responses of natural killer and T cells. *Nature* 382, 171–174.
- Thomas, R., 1991. Regulatory networks seen as asynchronous automata: a logical description. *J. Theor. Biol.* 153, 1–23.
- Thomas, R., Thieffry, D., Kaufman, M., 1995. Dynamical behaviour of biological regulatory networks—I. Biological role of feedback loops and practical use of the concept of the loop-characteristic state. *Bull. Math. Biol.* 57, 247–276.
- Thomas, R., Kaufman, M., 2001. Multistationarity, the basis of cell differentiation and memory. I. Structural conditions of multistationarity and other nontrivial behavior. *Chaos* 11, 170–179.
- Trinchieri, G., 1995. Interleukin-12: a proinflammatory cytokine with immunoregulatory functions that bridge innate resistance and antigen-specific adaptive immunity. *Annu. Rev. Immunol.* 13, 251–276.
- Usui, T., Nishikomori, R., Kitani, A., Strober, W., 2003. GATA-3 suppresses Th1 development by downregulation of Stat4 and not through effects on IL-12R $\beta$ 2 chain or T-bet. *Immunity* 18, 415–428.
- Yang, J., Zhu, H., Murphy, T.L., Ouyang, W., Murphy, K.M., 2001. IL-18-stimulated GADD45 $\beta$  required in cytokine-induced, but not TCR-induced, IFN- $\gamma$  production. *Nat. Immunol.* 2, 157–164.
- Yates, A., Callard, R., Stark, J., 2004. Combining cytokine signalling with T-bet and GATA-3 regulation in Th1 and Th2 differentiation: a model for cellular decision-making. *J. Theor. Biol.* 231, 181–196.
- Zhou, M., Ouyang, W., Gong, Q., Katz, S.G., White, J.M., Orkin, S.H., Murphy, K.M., 2001. Friend of GATA-1 represses GATA-3-dependent activity in CD4+ cells. *J. Exp. Med.* 194, 1461–1471.
- Zhou, M., Ouyang, W., 2003. The function role of GATA-3 in Th1 and Th2 differentiation. *Immunol. Res.* 28, 25–37.